

THE DEVELOPMENT OF FIRE DETECTION AND AUTOMATED FIRE EXTINGUISHER SYSTEM BY USING ARDUINO AND NODEMCU ESP 8266

A.R.Z. Abdul Latiff^{1,a}, Zulhaimi Mohammad^{2,b}

^{1,2}Instrumentation and Control Engineering,
Universiti Kuala Lumpur, Malaysian Institute of Technology (UniKL MITEC)
81750 Masai, Johor, Malaysia.

^arahman.latiff@s.unikl.edu.my, ^bzulhaimi@unikl.edu.my

*Corresponding author's
email :
zulhaimi@unikl.edu.my

Abstract

Human interruption has declined with the advancement in the field of mechanical science, and automated system are used for diverse works and for the protection of beings. Nowadays, fire mischances often keep occurrences especially at petrol station that can cause danger to human life and properties, also create difficulties to save lives for fire fighters from a catastrophe event. An automated fire extinguisher system is used in such situations to minimize the casualties from being damage and destroy. In order to locate and extinguish the flames, an automated fire extinguisher system should be able to detect the location of the fire when it begins and stop it before it starts to spread. Numerous scholars have expressed their interest in the implementation and development of the methodology applied in this project during the last decade. However, until now the implemented strategies have been less used, although most of them have demonstrated and understand the importance and benefit of this system. This project intended to design and create a prototype that has the function of detecting a fire and extinguish fire in the specific area. The project framework is developed using Arduino IDE software to distinguish obstacles and fires by using the three main sensors which is ultrasonic sensor, infrared flame sensor, radiofrequency sensor and MQ7 sensor by detecting the heat/flame, carbon monoxide gas, mobile phone frequency and vehicle entering the pump station. In addition, as a safety precautions and regulations, the ultrasonic sensor is used such when a vehicle enter the yellow box of the petrol pump station, the system will begin to run and operate. Finally, the automated fire extinguisher system will also alert the motorists by following the standard operation procedure at petrol station before they begin to refuel their vehicle. Once they have followed the standard operation procedure, only then they can proceed to refuel their vehicle with the safety measurement taken.

1.0 INTRODUCTION

This chapter contains the introduction to the issues which the research is concerned. This chapter will discuss on the background of study about the concept of detecting fire and to minimize the casualties by extinguishing the fire with automated fire extinguishing system. This chapter outline will consist of problem statement of issue being studied, the types of question that will be asked in research question, the aims and objectives of the study, the scope of study that will be focused on, the rationale and significance of the study.

A petrol station is a facility which sells fuel and lubricants oil for motor vehicles that you can easily buy and fill your vehicles tank, such as petrol or diesel. Even though a petrol station is a convenient facility which you can find mostly anywhere, it is still categorised as one of the most dangerous places because it contains gasoline or petrol vapours, which is highly flammable, and can be very dangerous if proper safety precautions are not followed. The most prevalent risks associated with gas station environment hazards are fires and explosions. We all

know that a gas stations are fire-prone areas and that is a fact, there is no argument about it. "According to the National Fire Protection Association, every year more than 5000 gas station fires are reported in the US. These fires cause plenty of damage. Talking in numbers, on an average, gas station fires cause 48 civilian injuries, 2 civilian deaths, and \$20 million in property damage every year." (JOHN W.KENNEDY COMPANY BLOG, 2018).

In a petrol station, everyone must follow the rules and standard operation procedure to avoid any casualties. But unfortunately, most of us takes thing lightly and not following the standard operation procedure that were given until it is too late. When not following the given standard operation procedure, it can lead to serious damage and casualties that can affect the surrounding and nearby people and innocent people at the petrol station. There are three common signs that you can find in every petrol station is to turn off the engine of your vehicle, turn off your cell phone and don't smoke or light a cigarette while refuelling the petrol.

2.0 EXPERIMENTAL

The project starts by doing some observations and research of previous works and some reviews about the development of fire detection and automated fire extinguisher system by journals and reference books. After that, the project proceeded with deciding the types of hardware's and software's that control the temperature, gas, distance, servo motor and pump for the primary process of the prototype.

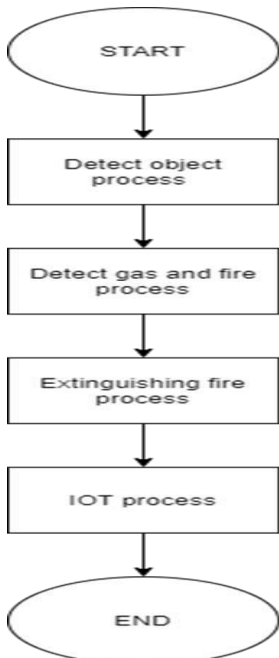

The first process is the detect object process, which will detect any object such as car for an example at a petrol station by using an ultrasonic sensor. The next process is the detect gas and fire process, which will

detect the gas by using MQ7 gas sensor when there is a presence of gas and will detect the fire by using IR flame sensor when there is a presence of fire. Then the next process is the extinguishing fire process, which will extinguish fire when there is a presence of fire. The last process is the IOT process.

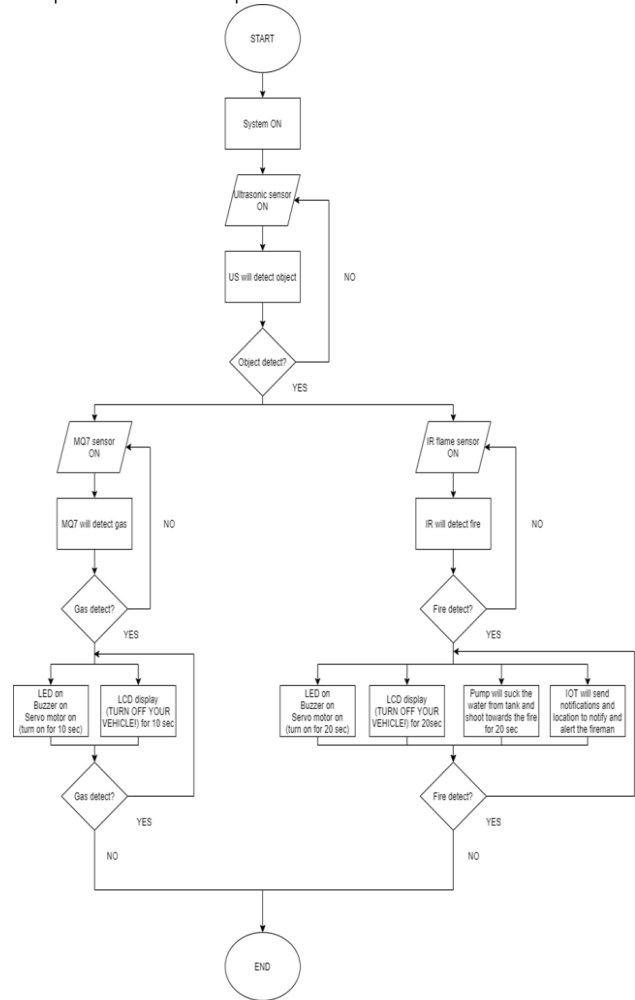

When the system is turn on, the ultrasonic sensor will be trigger. When the ultrasonic sensor is triggered, the ultrasonic sensor will turn on and will detect if there is any object within the range of distance that have been set. So, if there is an object is detected by an ultrasonic sensor, the MQ7 sensor and IR flame sensor will turn on. If there is no object is detected yet, the ultrasonic sensor will remain on and will be on standby mode until there is an object to detect it will proceed to the next process.

Once the MQ7 sensor turned on, the MQ7 sensor will detect if there is any presence of carbon monoxide gas. If there is a carbon monoxide gas detected, the LED, buzzer, servo motor and lcd will turn on as well for 10 seconds. The LED will turn red to indicate that there is a presence of carbon monoxide gas. The buzzer will produce a buzzing sound to alert people and the surrounding. While the servo motor will act as a lock for the trigger of the pump nozzle. Then the LCD will display "TURN OF YOUR VEHICLE NOW!". This process will complete for 10 seconds. After this process is complete, the LED,

buzzer, servo motor will turn off and the LCD will display "FIRE DETECTION AND AUTOMATED FIRE EXTINGUISHER SYSTEM". The MQ7 sensor will check again if there is a carbon monoxide gas is presence. If there is no carbon monoxide gas is presence, it will end the process.

Once the IR flame sensor turned on, the IR flame sensor will detect if there is any presence of fire. If there is a fire detected, the LED, buzzer, servo motor, pump, IOT and lcd will turn on as well for 20 seconds. The LED will turn red to indicate that there is a presence of fire. The buzzer will produce a buzzing sound to alert people and the surrounding. While the servo motor will act as a lock for the trigger of the pump nozzle. Then the pump will trigger and suck the water from a tank and shoot the water to extinguish the fire. At the same time, the IOT will send the notification and location through a software which is from Blynk to the fireman. Then the LCD will display "EXTINGUISHING FIRE NOW!". This process will complete for 20 seconds. After this process is complete, the LED, buzzer, servo motor, pump, IOT will turn off and the LCD will display "FIRE DETECTION AND AUTOMATED FIRE EXTINGUISHER SYSTEM". The IR flame sensor will check again if there is a fire is presence. If there is no fire is presence, then it will end the process.

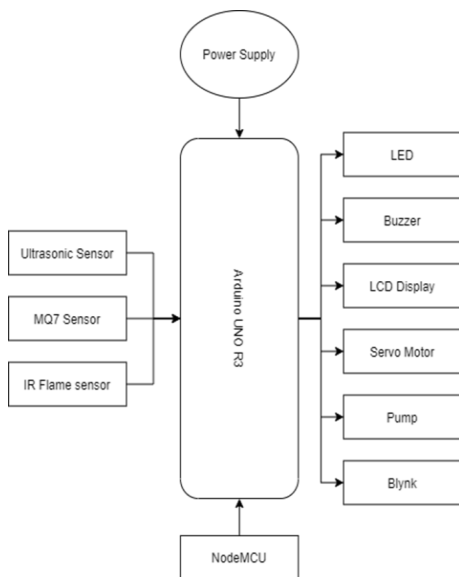

Basically, this is just the idea of the input and output for this project. The input of this project that were used is infrared flame sensor, MQ7 sensor and ultrasonic sensor. While the output of this project is LED, buzzer, LCD display, servo motor, pump and Blynk.

The outline of the methodology for this project is to achieve the objective and to accomplish the expected result while conducting this project. In this thesis report, the parameter measured is the ultrasonic sensor which the range is from 3cm to 40cm, MQ7 sensor is more than 100 value of the gas intensity, and IR flame sensor is 0 for ON and 1 is for OFF. The main objective of this project is to develop a fire detection and automated fire extinguisher system

by using ARDUINO and BLYNK IOT from NODEMCU. The microcontroller of the project is the Arduino system, and the prototype is designed and constructed by using Arduino UNO R3, relay, pump, ultrasonic sensor, infrared flame sensor, MQ7 sensor and NodeMCU.

The initial process of this project is programmed by using Arduino integrated development environment (IDE) and connected to the Arduino UNO R3 microcontroller. The system starts by measuring the initial vehicle inside the yellow parking box in petrol station partition. After detecting a vehicle by ultrasonic sensor, the main sensor for this prototype which is infrared flame sensor and MQ7 smoke sensor. Each sensor will continuously detect based on the parameter that were set for every sensor. For IR sensor, it will detect the presence of fire. If there is a presence of fire, a red led indicator will turn on and the servo motor will lock until there is no presence of fire. If there is no presence of fire, the led and buzzer will turn off. Same goes MQ7 sensor. For MQ7 sensor, it will detect the presence of vehicle engine still running. If there is a presence carbon monoxide gas that have been exhaust from a car, a red led indicator will turn on and the servo motor will remain lock until there is no presence of carbon monoxide gas.

When there is a presence of fire, the Blynk will turn on and send message and location to the manager of the petrol station to notify and inform the situation of the petrol station. Then the buzzer will automatically turn on which act as a siren to make everyone stay alert. The pump will also turn on and the extinguishing fire process will begin here for 1 minute. After 1 minute, if there is no presence of fire left, the buzzer and the pump will turn off, and the system will end. As long as the fire is still presence, the pump will turn on as well and the process will keep looping until the fire is fully extinguish and there is no presence of fire left.

Hardware Development:

1) Ultrasonic Sensor

The ultrasonic sensor in this project prototype is used for detecting any vehicle that pass through and stay stationary at the yellow box of every pump partition station. If there is any vehicle is presence within range of 50° to 130° the ultrasonic sensor will transmit and receive the wave signal from the vehicle.

An ultrasonic sensor is an electronic system that emits ultrasonic sound waves, measures the distance of a target object and transforms the reflected sound into an electrical signal. Ultrasonic waves move faster such as the sound that humans can hear than the speed of audible sound. Ultrasonic sensors have two main components which is the transmitter which uses piezoelectric crystals to emit the sound, while the receiver which is after it has travelled to and from the target that have encounters the sound).



2) Infrared Flame Sensor

The infrared flame sensor in this project prototype is used for detecting fire before and during refueling petrol. Before refueling is used to check if there is any presence of fire cigarettes and after refueling is used to check if there is any presence of fire such as spark during refueling the petrol.

An infrared (IR) sensor is an electronic device which in its surrounding environment, measures and detects infrared radiation. Infrared radiation was observed inadvertently in 1800 by an astronomer called William Herchel. He found that the temperature just above the red light was the highest when calculating the temperature of each color of light (separated by a prism). As the wavelength is longer than that of visible light (although it is also on the same electromagnetic spectrum), IR is invisible to the human eye. All that emits heat gives off infrared radiation (everything that has a temperature above about five degrees Kelvin).



3) MQ7 Sensor

For the detection of carbon monoxide gas emitted by exhaust vehicles, the MQ7 sensor is used in this project prototype. If carbon monoxide gas is present, we presume that the car engine is still working and some kinds of gases, including carbon monoxide gas, have been created by car exhaust. The MQ7 is a carbon monoxide (CO) sensor that is easy to use and is ideal for detecting CO concentrations in the air. It can detect concentrations of CO-gas from 20 to 2000ppm anywhere. MQ7 is extremely carbon monoxide susceptible and has a stable and long life cycle.



4) Relay

In this project prototype, the relay module is a programmable electrical switch that can be operated by any micro-controller or Arduino. It is used to monitor on/off machines that use high voltage and/or high current, programmatically.

To use an Arduino to control high-voltage or high-power circuits, you must separate them with a relay from the Arduino. An Arduino does not directly control circuits which operate at high voltages or at high currents. Instead to control a relay that is capable of handling and switching high voltage or high-power circuits, you use a low-voltage control signal from the Arduino. A relay consists of an electromagnet that allows a switch to close or open when energized. Between the control circuit and the circuit being monitored, relays provide full electrical separation.

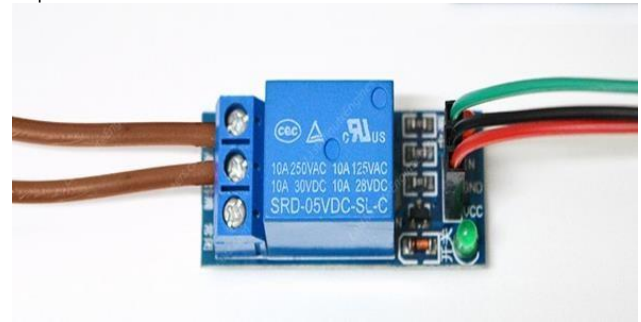

5) Pump 240V

The 240V pump in this project prototype is used for moving the water from the tank through a pipe which will be placed at the inlet and outlet of the pump. This pump will act as fire extinguisher to extinguish the fire in this project. The pipe will be attached with atomizing nozzle.

A water booster pump helps to raise the water pressure and volume that comes from the head of your faucet or tub. A inconvenience is life with low water pressure. If you have wanted to shower under a trickle of water and just had to spin around in circles to get wet, you're well aware of that. Low water pressure may make basic activities such as bathing or brushing your teeth a hassle, so the ideal solution could be a booster pump.



6) Servo Motor

The servo motor in this project prototype is used for locking the main valve of the petrol pump. It is for safety precaution and regulation to avoid from fire to trigger. A Servo Motor is a small system that has a shaft for output. This shaft can be placed at specific angular positions by sending a coded signal to the servo.

The servo will preserve the shaft's angular position as long as the coded signal exists on the input line. The angular position of the shaft will change if the coded signal changes. Servos are used in practice for positioning control surfaces such as elevators and rudders in radio-controlled airplanes. They are also used in vehicles, puppets, and, of course, robots that are radio-controlled.

The Servos are particularly useful in robotics. The engines are lightweight, have built-in control circuitry, and are highly effective for their scale. In a standard servo, such as the Futaba S-148, there is 42 oz / inches of torque, which is decent for its size. It also draws power equal to the mechanical load. A lightly loaded servo, therefore, doesn't consume much energy.



7) Arduino UNO R3

Arduino UNO R3 is a microcontroller of Arduino with the program Arduino Integrated Development Environment (IDE) as the software to program the process. All sensors are connected to the microcontroller. Arduino has two different types of pin; digital and analog.

To provide input and receive output from the sensors, these two types of pin are used. The digital pins can read the switching on and off conditions set in the software. For perfect calculation of all actual or real values, analog pins are appropriate. For the software to read, this pin can convert the input into digital values.



Description	Details
Operating Voltage	5V
Input Voltage	6V-20V
Digital I/O pins	14 Pins
Analog Input Pins	6 Pins
Flash Memory	32KB
Clock Speed	16MHz

8) NodeMCU

The NodeMCU ESP8266 development board comes with the ESP-12E module containing ESP8266 chip having Tensilica Xtensa 32-bit LX106 RISC microprocessor. This microprocessor supports RTOS and operates at 80MHz to 160 MHz adjustable clock frequency. NodeMCU has 128 KB RAM and 4MB of Flash memory to store data and programs. Its high processing power with in-built Wi-Fi / Bluetooth and Deep Sleep Operating features make it ideal for IoT projects.

NodeMCU can be powered using Micro USB jack and VIN pin (External Supply Pin). It supports UART, SPI, and I2C interface.

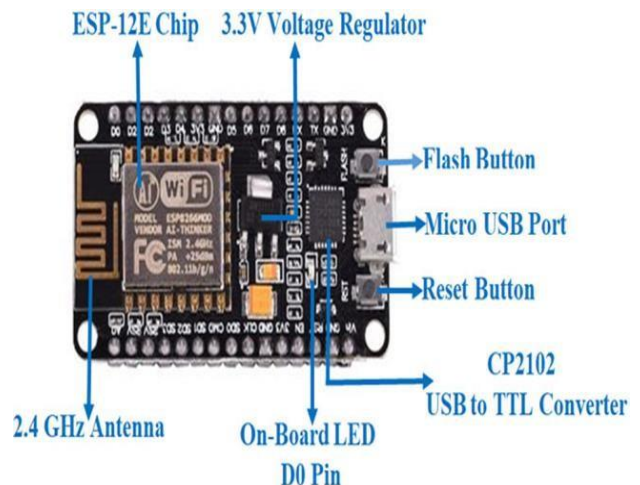

Software Used:

1) Arduino IDE

For coding the Arduino UNO R3 and NodeMCU ESP8266, I use Arduino IDE to act as a platform when encoding the electronic component. The abbreviation IDE stands for Integrated Development Environment. This programmed is written using C and C++ functions. It is used for composing, compiling and uploading programmed to boards compatible

with Arduino. Almost all Arduino modules are compatible with this software. Besides, it is an open source and is ready to install to start programming a code.



2) Blynk

The Blynk module in this project prototype is used for sending message and location to the manager and firefighter department based on the situation of the fire. The message will be sent to the manager of the petrol station and firefighter department. This is an IOT that will inform and notify the person in charge on what is going and happening in the actual incident. Blynk was created with the Internet of Things in mind. It has the ability to manage hardware remotely, show sensor data, save data, visualize it, and perform a variety of other fascinating things. The platform is made up of three primary components: Blynk App enables you to create stunning interfaces for your projects by combining multiple widgets.

Blynk notification at the Blynk app software on a smartphone. Here is the result for IOT system for this project. As you can see it displays "Fire At Petrol Station Happening Now At Petronas Seri Alam 81750 Masai, Johor". This notification and location were received from the serial monitor and sent it to the manager of the petrol station and to the fire department.

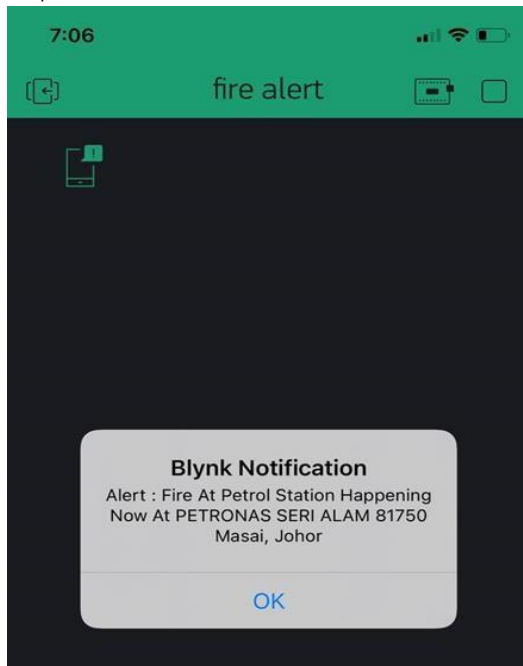

3) Fritzing

The Arduino Uno R3 diagram is sketch and design in Fritzing software. The diagram explains about the input and output tag for the whole equipment that is used in the prototype of the Development Fire Detection and Automated Fire Extinguisher System. As stated above, there are several equipment that are connected directly to the software as an input.

Most of the components were connected to the digital output port, whereas the MQ7 sensor and LCD display is the only component that was connected to the analog output port in the Arduino UNO R3 board.

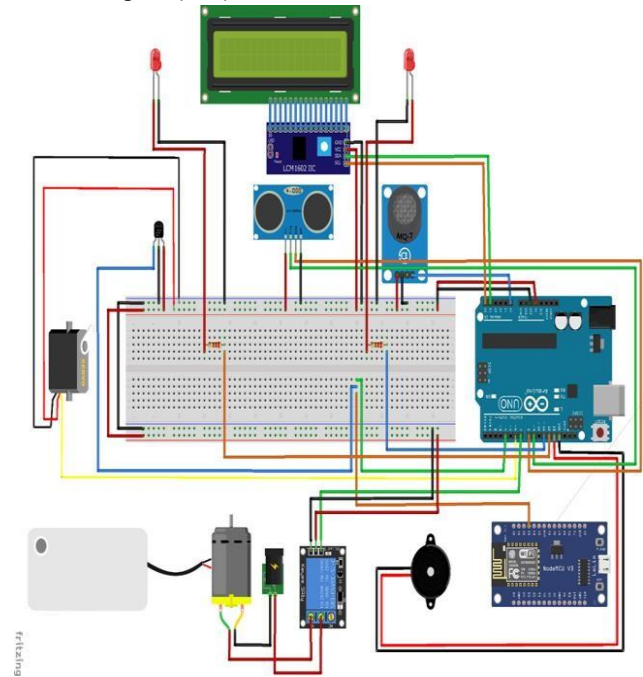

Wiring

Figure 4.3.9 shows that the wiring circuit in the prototype. The power bank was used as a power source to power up and turn on the system. The 2.1 A port is used to power up the Arduino in the prototype, while the other port which is 1.0 A is used to power up the NodeMCU in the prototype in order to use the IOT for Blynk notifications for the system.

Most of the components were connected to the digital output port, whereas the MQ7 sensor and LCD display is the only component that was connected to the analog output port in the Arduino UNO R3. The components that are connected to the digital output of Arduino microcontroller are IR flame sensor, pump, servo motor, LED, buzzer, NodeMCU, ultrasonic sensor and a single channel relay. All components are connected to the digital output of Arduino microcontroller pins 4, 6, 7, 8, 9, 11, 12, 13. An analog output of Arduino microcontroller pins is for MQ7 sensor which is in port A0 and the LCD display which is in port A4 and A5.

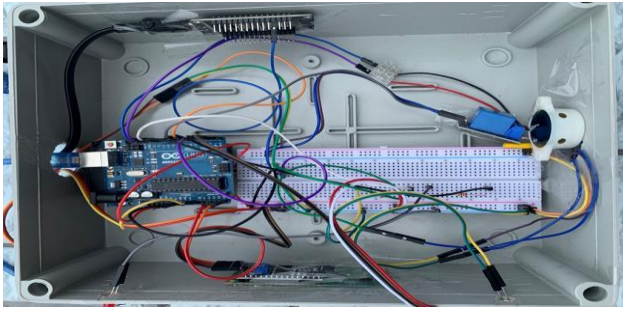

3.0 RESULTS AND DISCUSSION

The Results for The Development of Fire Detection and Automated Fire Extinguisher System.

This chapter will summarize and further discusses on the troubleshooting process, hardware and software setup, and the results obtained from the project. After about 5 months of hard work, The Development of Fire Detection and Automated Fire Extinguisher System a is finally completed earlier than the expected period. The prototype built is able to run the desired process of extinguishing fire. Based on the prototype, the result is obtained and analysed.

In this chapter, the results of the study are presented and discussed regarding the objectives of the study, which was The Development of Fire Detection and Automated Fire Extinguisher System by using Arduino UNO R3. The two sub aims – To design a prototype that able to extinguish fire when it detects flame. From the development of fire detection and automated fire extinguisher system by using Arduino Uno and Blynk IOT from NodeMCU that enable to control and monitor the precision of extinguishing fire.

Hardware Development:

1) Distribution Board



Figure 23 4.3.1 Distribution Board Prototype

Figure 4.3.1 shows that the distribution for the Development of fire Detection and Automated Fire Extinguisher system by Arduino Based. The distribution board was designed and built to ease the user to run the prototype.

2) Power Bank



Figure 24 4.3.2 Power bank

Figure 4.3.2 shows the power bank were used as a power source to power up and turn on the system. The 2.1 A port is used to power up the Arduino in the prototype, while the other port which is 1.0 A is used to power up the NodeMCU in the prototype in order to use the IOT for Blynk notifications for the system.

3) Prototype Power On



Figure 25 4.3.3 Prototype Power On

Figure 4.3.3 shows that when the prototype has been powered up by the power bank, the system will automatically run-in idle mode. Once the system is started, the first electrical components that will turn on is the ultrasonic sensor. When the ultrasonic sensor is turned on, it will detect if there is any object within the range.

During this process, the LCD display will show on the screen "AUTOMATED FIRE EXTINGUISHER SYSTEM". It shows that the prototype system is working properly and ready to proceed with the next step and process. Once the ultrasonic sensor detects an object within the range, the MQ7 sensor and IR flamesensor will trigger as well.

4) MQ7 Process



Figure 26 4.3.4 MQ7 Sensor Process

Figure 4.3.4 shows that MQ7 process started when the ultrasonic sensor detects an object within the range. The MQ7 sensor will trigger and ready to detect if there is any presence of carbon monoxide gas.

If there is a presence of carbon monoxide gas is detected, the LED will turn on to indicate that there is a presence of carbon monoxide gas. Next, the servo motor will trigger to lock the trigger of the pump nozzle so that the driver cannot proceed to refuel their car or motor vehicle if there is carbon monoxide gas presence. The buzzer will produce a loud sound to alert the driver to turn off their vehicle as soon as possible. Same goes to the LCD screen, it will display "TURN OFF YOUR VEHICLE RIGHT NOW!". This process will be taken for 10 seconds. After 10 seconds, all the components will be back to default phase where the LED will turn off and the servo motor will unlock. The LCD screen will display "AUTOMATED FIRE SYSTEM".

5) IR Flame Process



Figure 27 4.3.5 IR Flame Sensor Process

Figure 4.3.5 shows that IR flame sensor process started when the ultrasonic sensor detects an object within the range same as the MQ7 sensor process mentioned above. The IR flame sensor will trigger and ready to detect if there is any presence of fire.

If there is a presence of fire is detected, the LED will turn on to indicate that there is a presence of fire. Next, the servo motor will trigger to lock the trigger of the pump nozzle so that the driver cannot proceed to refuel their car or motor vehicle if there is a present of fire. The buzzer will produce a loud sound to alert the driver and surrounding that there is a fire happening.

The pump will trigger and starts to extinguish the fire. Same goes to the LCD screen, it will display "EXTINGUISHING FIRE RIGHT NOW!". At the same time, the Blynk will sends notifications to the manager and the fire department. This process will be taken for 20 seconds. After 20 seconds, all the components will be back to default phase where the LED will turn off, the servo motor will unlock, the pump will turn off and the Blynk will turn off as well. The LCD screen will display "AUTOMATED FIRE EXTINGUISHER SYSTEM".

If there is still a presence of fire after the 20 second process, the system will proceed back as the initial to the end where when the fire is detected and extinguish the fire until there is no more presence of fire. This process will keep looping and repeating until there not any single fire in the area left.

6) Pump After Extinguishing

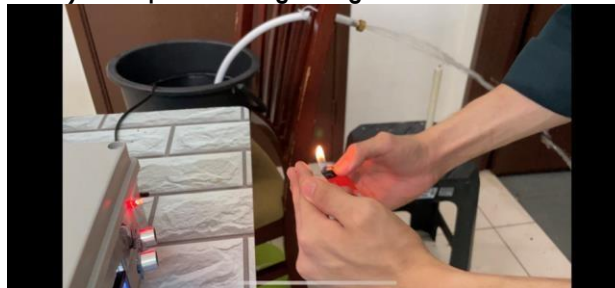

Figure 30 4.3.8 Pump After Extinguishing

Figure 4.3.8 shows that the pipe nozzle shoot the water from the pump and extinguish the fire effective immediately for 20 seconds right after the IR flame sensor detects a presence of fire.

Software Development

Arduino IDE is the main software for code sketching, while Blynk is application to get notifications and location of fire happening at petrol station. Serial communication is required when you want to transfer sensor data or any data from one device to another device, in our case it is ESP8266 NodeMCU and Arduino. In order to use a serial communication between Arduino UNO R3 and NodeMCU ESP8266, it need to wire the RX/TX pin from Arduino to available pin that has been declare on NodeMCU coding. Then, it needs two different coding which is suit between Arduino UNO and NodeMCU ESP8266. First, get the Software Serial library of Arduino. Then, if the wiring is all set, just upload the code that been sketch to the Arduino and NodeMCU.

```
test_fire_no8
//Blynk Fire Alarm Notification
#define BLYNK_PRINT Serial
#include <ESP8266WiFi.h>
#include <BlynkSimpleEsp8266.h>
BlynkTimer timer;
char auth[] = "e9esaP_I-C8JQ6aTGBrT3jCvQq1ANOW"; //Auth code sent via Email
char ssid[] = "Barasatais@unifi"; //Wifi name
char pass[] = "hidupbarasatais123"; //Wifi Password
int flag=0;
void notifyOnFire()
{
  int isButtonPressed = digitalRead(D3);
  if (isButtonPressed==1 && flag==0) {
    Serial.println("Alert : Fire At Petrol Station Happening Now At PETRONAS SERI ALAM 81750 Masai, Johor");
    Blynk.notify("Alert : Fire At Petrol Station Happening Now At PETRONAS SERI ALAM 81750 Masai, Johor");
    flag=1;
  }
  else if (isButtonPressed==0)
  {
    flag=0;
  }
}
void setup()
{
  Serial.begin(9600);
  Blynk.begin(auth, ssid, pass);
  pinMode(D3, INPUT_PULLUP);
  timer.setInterval(1000L,notifyOnFire);
}
void loop()
{
  Blynk.run();
  timer.run();
}
```

Figure 38 4.4.7 NodeMCU Coding

Figure 4.4.7 shows the coding for NodeMCU used in The Development of fire Detection and Automated fire Extinguisher System is program by using the Arduino IDE software. First of all, we need to declare the serial of the module in the software. For

this coding we need to link and connect to the wifi in order to get the notifications as an IOT. A token will be sent in the Blynk app and sent to the email. The token needs to be declared in the coding as well to tally between the coding and the app in the real time.

For the "serial.begin" line, it sets the data rate in bits per second (baud) for serial data transmission. In this case, 9600 is being selected for a slower rate of data transmission. It allows for easy data collection and monitoring of process.

Here is the result for IOT system for this project. As you can see it displays "Fire At Petrol Station Happening Now At Petronas Seri Alam 81750 Masai, Johor". This notification and location will print and send to the Blynk app software.

Blynk Notification

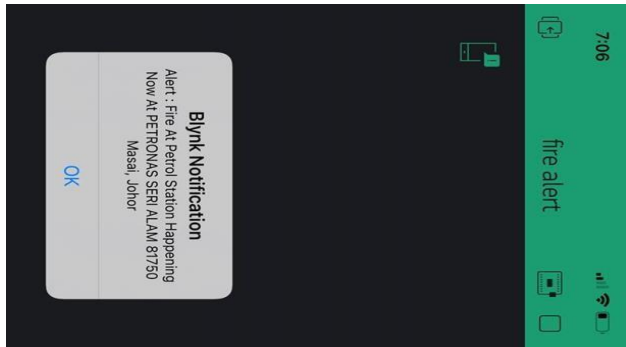

Figure 40 4.4.9 Blynk Notification

Figure 4.4.9 shows the Blynk notification at the Blynk app software on a smartphone. Here is the result for IOT system for this project. As you can see it displays "Fire At Petrol Station Happening Now At Petronas Seri Alam 81750 Masai, Johor". This notification and location will receive from the serial monitor and send it to the manager of the petrol station and to the fire department.

Data Analysis:

1) Gas Against Time

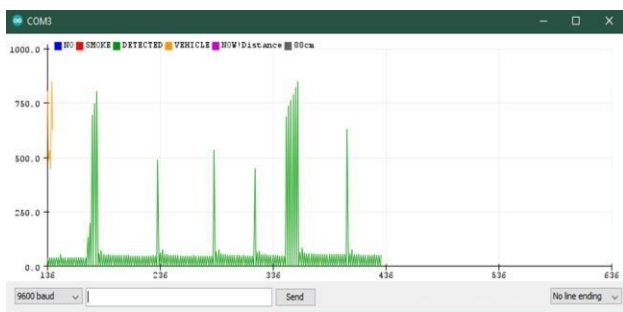

Figure 41 4.5.1 Gas Against Time

Figure 4.5.1 shows that the gas against time. Based on the graph in the figure above, it shows that the initial value for the intensity of the gas is 0. When the system starts and the MQ7 sensor triggered, the

value of the gas will start at 0. When MQ7 sensor detects a carbon monoxide gas, there will be a spike jump because the value of gas is not fixed based on how much the gas is produced.

When the MQ7 sensor detects any value of gas that is more than 100, that shows there is a presence of a carbon monoxide gas. For the first spike, you can see it goes all the way up to 750. This is because the intensity of the gas is very high. After 10 seconds, the spike will drop back around 34 because that is the idle value when there is no presence of a gas. Same goes to the 2nd spike all the way to the 6th spike in the graph, when it detects a carbon monoxide gas it will jump to a high value and after 10 seconds it will drop back to 34. This process will keep on repeating the same whenever the MQ7 sensor detects a carbon monoxide gas.

2) Infrared Flame Value Against Time

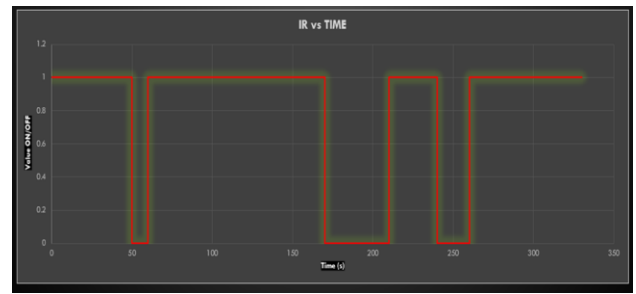

Figure 42 4.5.2 Infrared Flame Value Against Time

Figure 4.5.2 shows that the infrared flame value against time. Based on the graph in the figure above, it shows that the initial value for fire is 1. When the system starts and the IR flame sensor triggered, the value of the fire will start at 1. When the IR flame sensor detects a fire, the graph will drop and descend to 0. This is because the IR flame sensor is a digital output port or also known as D0.

When the IR flame sensor detects a fire, the value of the IR flame will drop to 0. That shows there is a presence of a fire. For the first drop, you can see it drops all the way down to 0. This is because the IR flame sensor is a digital output. After 20 seconds, the graph will ascend back to 1 because that is the idle value when there is no presence of a fire.

For the second descend, the time taken was for 60 seconds. This is because the process of extinguishing fire is continuously repeating for 3 times in a row. This shows that whenever the system detects a fire after the extinguishing process, the system will keep on extinguishing the fire until there is no more fire detected and the value will jump back to the value of 1. Same goes to the third process, the time taken was for 40 seconds. After 40 seconds, there is no more fire detected by the IR flame sensor, the value will ascend back to 1.

4.0 CONCLUSION

As a conclusion, the project where it is designed in order to detect fire and automatically extinguish fire by using the Arduino platform and NodeMCU. The project prototype is considered as fully functional project based on the working performance and capability. In addition, all of the objective of The Development of Fire Detection and Automated Fire Extinguisher System project were achieved and accomplished successfully.

Firstly, this project prototype is one of the fastest and quickest way to extinguish fire when there is a presence of fire. Next by applying an Internet of Things to the system by sending notification and location to the fire department and manager when fire occur, it will ease both parties of fire department and the manager. Then the people who are in the accident of fire at petrol station will get rescue from fireman faster if things get badly and out of control. Lastly, this study has shown that this prototype will ensure the safety of people at the petrol station and the surrounding as well. This project prototype can be easily implemented in any petrol station at Malaysia with ease and the rate of incident and accident at petrol station will decrease drastically.

Recommendation:

Although the project prototype of The Development of Fire Detection and Automated Fire Extinguisher System is a success, it still has some improvements that can be made for future work.

- 1) The IR flame sensor can be added a few more on the project prototype. Add one at the top of the prototype, one at the side of right corner of the prototype and add one more behind the prototype. With this it can be a detect the fire at any angle.
- 2) Using an image processing system for this project is perfect. It can be more accurate and precise in order to detect the flame instantly anywhere and any angle.
- 3) Redesign and relocate the configuration of the pipe for extinguish fire, which will make the extinguishing process more precise by adding a servo motor on it so that it can move sideways and horizontally during extinguishing process.

Limitation:

The limitation stated below is referred to the experience while running the prototype and also compatibility issues.

- 1) The Blynk application has a device compatibility issue and some cases only work on android smartphone.
- 2) SIM800L GPRS GSM Module 4 World Frequency cannot connect to Malaysia server. Malaysia sim card does not register in global network for GSM module 800L.

- 3) Radio frequency sensor that I wanted to use for this project is not available in Malaysia and hard to find. there is nowhere to be found in local unless get it from overseas version which is very costly.
- 4) Arduino had the tendency of difficulties connecting to the internet. A developer may have shields and libraries, but the process is not straightforward. if the project requires one to write sophisticated software or requires entire software stacks or protocols, then Arduino may not be suitable.

Acknowledgement

All praises are to Allah, Lord of the Universe, the Merciful and Beneficent to Prophet Muhammad S.A.W, His Companion, and the people who follow His path. First and foremost, like to thank Almighty Allah for giving good health and wellbeing that were necessary for completing this thesis for the final year project. I would also like to take this opportunity to express my sincere gratitude and appreciation to my parents and my family for the unceasing encouragement, support and attention. Also, special appreciation goes to my supervisor, Ts. Zulhaimi Bin Mohammad for his supervision and constant support. His invaluable guidance of constructive comments and suggestions throughout the drafting and thesis works have contributed to the success of this research and not forgotten, my appreciation to my co-supervisor, Dr. Ainul Hakimah Binti Karim for her support and knowledge regarding this topic. Moreover, I would like to thank my classmates and colleagues for sharing their knowledge and opinion regarding to this project. Finally, I am very thankful to everyone on contributing, directly and indirectly, helping to succeed in making the final year project entitled "Fire Detection and Automated Fire Extinguisher System". I am making this project not only for marks but to also increase my knowledge in this field and course. Thanks again to everyone who helped throughout this journey, I really appreciated it from the bottom of my heart.

References

[1] J. van der Geer, J.A.J. Hanraads, R.A. Lupton, The art of writing a scientific article, *J. Sci. Commun.* 163 (2000) 51-59.

Reference to a book:

[2] W. Strunk Jr., E.B. White, *The Elements of Style*, third ed., Macmillan, New York, 1979.

[1] NEW STRAITS TIMES – A burning issue
<https://www.nst.com.my/opinion/leaders/2017/11/30/4224/burning-issue>

- [2] Int.J.Curr.Res.Aca.Rec.2014; Special Issue-1 (October-2014):1-4, Event Tree Analysis for Analyzing Probable Fire Scenario in the Plastic Manufacturing Extra Building
<http://www.ijcrar.com/special/1/A.Ketsakorn%20and%20W.Meethom.pdf>
- [3] [4] Analysis of Safety Decision-Making Data Using Event Tree Analysis
https://lib.dr.iastate.edu/cgi/viewcontent.cgi?referer=https://www.google.com/&httpsredir=1&article=1351&context=abe_eng_conf
- [5] [6] [7] Event Tree Analysis Wikipedia
https://en.wikipedia.org/wiki/Event_tree_analysis
- [8] Fault Tree Analysis
<https://www.weibull.com/basics/fault-tree/index.htm>
- [9] The Owner's Role in Project Risk Management
<https://www.nap.edu/read/11183/chapter/6>
- [10] [11] Fire Risk Overview-Fire Risk Assessment Guidance for Various Premises, March 28, 2011
<https://www.firesafe.org.uk/fire-risk-assessment/>
- [12] Clemens-PL; Simmons-RJ, NIOSH 1998 Mar; :1- 208, System safety and risk management: NIOSH instructional module.
<https://www.cdc.gov/niosh/nioshtic-2/20000060.html>
- [13] Hazards of Flammable Gases, Liquids and Aerosols and Risk Minimization
https://ehs.unl.edu/sop/s-hazards_flam_gases_liq_aeros_risk_min.pdf
- [14] Characteristics of Light Sources
<https://www.sciencedirect.com/topics/engineering/luminous-flux>
- [15] Pressure
https://www.princeton.edu/~asmits/Bicycle_web/pressure.html
- [16] Physics of Diving
<https://www.ehs.ucsb.edu/files/docs/ds/physics.pdf>
- [17] The Atmosphere and The Weather
<http://www.atmo.arizona.edu/students/courselinks/all12/atmo336/lectures/sec1/mvparcels.html>
- [18] Temperature and Thermometers
<https://www.physicsclassroom.com/class/thermalP/Lesson-1/Temperature-and-Thermometers>
- [19] Kelvin Temperature Scale: Facts and History
<https://www.livescience.com/39994-kelvin.html>
- [20] An Introduction to Fire Detection, Alarm, and Automatic Fire Sprinklers
<https://www.nedcc.org/free-resources/preservation-leaflets/3.-emergency-management/3.2-an-introduction-to-fire-detection,-alarm,-and-automatic-fire-sprinklers>
- [21] Smoke Detector
<http://www.expertfireengineers.com/alarm-smoke.html>
- [22] James S.Aber, Johannes B.Ries, IreneMarzloff; Image Processing and Analysis
<https://www.sciencedirect.com/science/article/pii/B9780444532602100110#!>
- [23] Introducing Data Mining and Knowledge Discovery
https://www.researchgate.net/publication/314531242_Introducing_Data_Mining_and_Knowledge_Discovery
- [24] Basic Electronics Tutorial
<https://www.electronics-tutorials.ws/io/thermistors.html>
- [25] El Sensor Technologies; 507-345-5786; sales@ai-sensor.com
<https://www.ei-sensor.com/what-is-a-thermistor/>
- [26] A Guide to the Applications of Flame
<https://www.azosensors.com/article.aspx?ArticleID>
- [27] A Stochastics Approach for Determining Fire Size and Classification in Fire Risk Analysis and Monitoring; Rostam Salleh.